

# M16-M30, Electric Torque Shear Wrench



Model Number : ZJW-22J,ZJW-24J,ZJW-30J

Rated Voltage:220V 50Hz

Max power consumption: 1300w

Max torque: 1200N.m

Main body weight: 5, 5.5, 7.5KG

Ro speed(min-1): 16, 14, 5rpm

Aaptable bolt dia: M16, M20, M22, M24, M30 / 5/8", 3/4", 7/8", 1"

# M16-M30, Electric Torque Shear Wrench

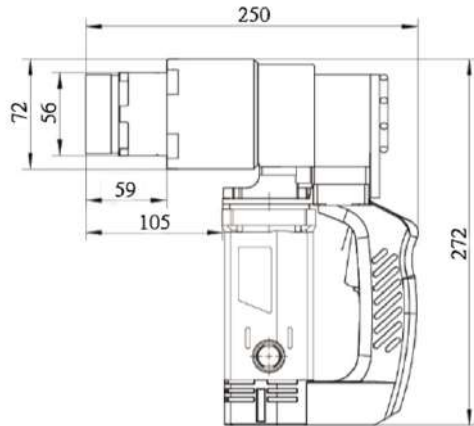

ZJW-22J Electric Torque Shear Wrench

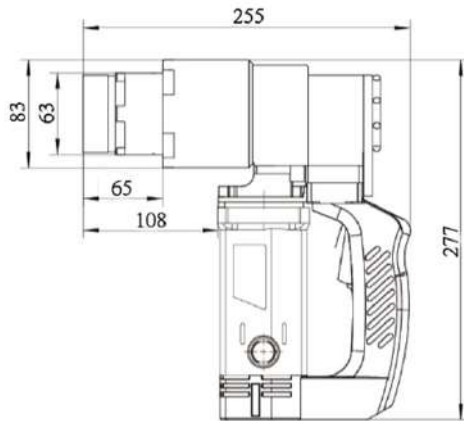

ZJW-24J Electric Torque Shear Wrench

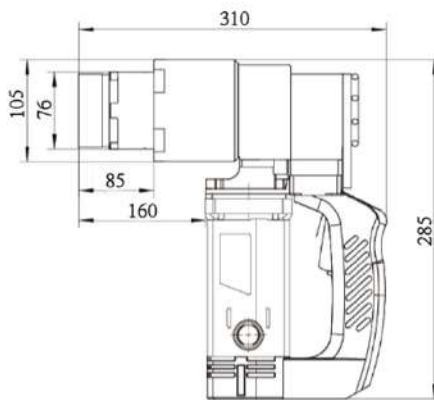

ZJW-30J Electric Torque Shear Wrench

# M16-M30, Electric Torque Shear Wrench

Electric Torque Shear Wrench						
Model Number	Rated Voltage	Max. Current	Max. Power	Ro Speed	Weight	Bolt Type
		A	W	r/min	Kg	
ZJW-22J	220V 50Hz	4	1200	16	5	M16-M22
ZJW-24J	220V 50Hz	5	1300	14	5.5	M16-M24
ZJW-30J	220V 50Hz	6	1300	5	7.5	M24-M30