

# Radial piston pump type R and RG with several pressure connections

## Product documentation



Operating pressure $p_{\max}$ :	700 bar
Geometric displacement $V_{g \max}$ :	53.5 cm <sup>3</sup> /rev
Flow rate $Q_{\max}$ :	76.0 lpm (1450 min <sup>-1</sup> )



© by HAWE Hydraulik SE.

The reproduction and distribution of this document as well as the use and communication of its contents to others without explicit authorisation is prohibited.

Offenders will be held liable for the payment of damages.

All rights reserved in the event of patent or utility model applications.

Brand names, product names and trademarks are not specifically indicated. In particular with regard to registered and protected names and trademarks, usage is subject to legal provisions.

HAWE Hydraulik respects these legal provisions in all cases.

Printing date / document generated on: 17.02.2021

# Contents

<b>1</b>	<b>Overview of radial piston pump types R and RG.....</b>	<b>4</b>
1.1	Application.....	5
1.2	Basic types.....	5
1.3	Design.....	5
1.4	Assemblies.....	5
1.5	Sectional model of a double radial pump (assembly 6012).....	6
<b>2</b>	<b>Available versions, main data.....</b>	<b>7</b>
2.1	Order coding.....	7
2.2	Pump types and combinations.....	8
2.3	Pressure connection characteristics.....	20
2.4	Motor.....	21
<b>3</b>	<b>Parameters.....</b>	<b>24</b>
<b>4</b>	<b>Dimensions.....</b>	<b>26</b>
4.1	Assembly 7631.....	26
4.2	Assembly 6010.....	27
4.3	Assembly 6011.....	28
4.4	Assembly 6012.....	30
4.5	Assembly 6014.....	32
4.6	Assembly 6016.....	33
<b>5</b>	<b>Assembly, operation and maintenance recommendations.....</b>	<b>35</b>
5.1	Intended use.....	35
5.2	Assembly information.....	35
5.2.1	Venting and commissioning.....	35
5.2.2	Pump positioned outside of oil tank.....	36
5.2.3	Installation in oil tank.....	36
5.2.4	Available bleeding parts.....	37
5.3	Operating instructions.....	38
5.4	Disposal information.....	38
<b>6</b>	<b>Other information.....</b>	<b>39</b>
6.1	Accessories, spare parts and separate components.....	39

**1****Overview of radial piston pump types R and RG**

The radial piston pump types R and RG have a closed pump housing. Therefore, besides use as a motor pump outside an oil tank, installation in the container of a hydraulic power pack is also possible (see [D 6010 H](#)). The radial piston pump is available with several pressure outlets which enable the same or several different flow rates. The radial piston pump type RG has plain bearings which have a longer lifetime. This type is therefore used in extreme operating conditions. Extremely high flow rates can also be achieved by arranging up to 6 radials in parallel. When the radial piston pump is used in the hydraulic power pack, it is suitable for use as a highly compact control system. Connection blocks and valve banks can be mounted on the cover plate of the hydraulic power packs.

**Features and benefits:**

- Good function even at low viscosity
- High level of efficiency
- Compact dimensions
- Fine flow rate gradation

**Intended applications:**

- Any high-pressure application is basically possible.
- Areas in which a constant flow rate is necessary.
- Press construction
- Fixture design
- Testing and laboratory equipment
- Lubrication systems
- Agricultural engineering
- etc.



Radial piston pumps type R and RG

## 1.1 Application

The pumps are generally used to supply hydraulic oil to hydraulic consumers in oil-hydraulic systems. Maximum installable hydraulic power 30 kW.

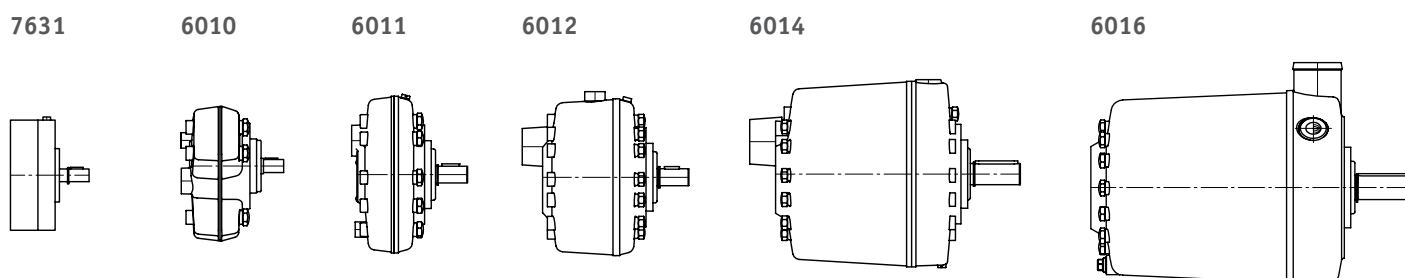
## 1.2 Basic types

- R** - Classic version with roller bearing as eccentric bearing, also suitable for very low rotation speeds
- RG** - Version with plain bearings as eccentric bearings, well suited to media with low lubricity (e.g. HFC), not suitable for low rotation speeds as the necessary lubricant film cannot be built up.

## 1.3 Design

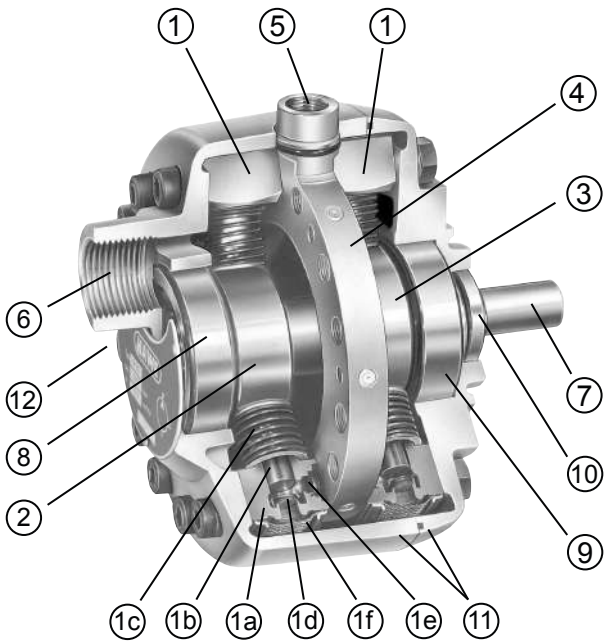
The radial piston pumps are valve-controlled with cylinders in a radial arrangement. The cylinder radials, arranged in one, two or more superimposed layers (rows), are driven by bearings fitted eccentrically on the drive shaft (piston pressure stroke), and reset by a spring (piston suction stroke). The delivery flows of the individual cylinders are brought together in collecting plates feeding a joint pressure connection (P). The housing shells are load-bearing elements supporting the cylinders and shaft bearings. The pumps are largely statically and dynamically balanced, resulting in smooth running. With the exception of the 1 and 2-cylinder pumps, an uneven number of pistons is used per cylinder radial, so that the pulsation of the delivery flow is minimised from three cylinders upwards.

## 1.4 Assemblies



Type MPE.. cylinders are installed in assembly 7631. All other assemblies (type 6010 – 6016) are fitted with type PE.. cylinders.

## 1.5 Sectional model of a double radial pump (assembly 6012)



- 1 Pump cylinder, consisting of:
  - 1a Cylinder
  - 1b Piston
  - 1c Return spring for the suction stroke
  - 1d Integrated suction valve
  - 1e Integrated pressure control valve
  - 1f Strainer insert, protects against coarse contamination
- 2 Rear eccentric bearing for the pressure stroke
- 3 Front eccentric bearing for the pressure stroke
- 4 Hydraulic oil manifold
- 5 Hydraulic oil outlet (pressure connection)
- 6 Suction port
- 7 Drive shaft
- 8 Rear shaft bearing
- 9 Front shaft bearing
- 10 Shaft seal
- 11 Housing
- 12 Type plate

## 2 Available versions, main data

The number of delivery flow codings indicates how many pressure connections there are. The order of the various flow rates defines the order of pressure connections (P1 - P..), e.g. R 2.2 - 1.2.

For 1-radial pumps: The first coding specifies the overall cylinder group.

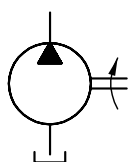
For multi-radial pumps: The first coding specifies the overall cylinder radials.

Assembly 6011 1-radial pumps with 7 cylinders are not available with six pressure connections. This also applies if a cylinder radial on a 2-radial pump is divided into several pressure connections. If you require more pressure connections, the respective cylinders can be grouped externally for a pump with seven connections.

See [Chapter 4](#).

### 2.1 Order coding

Circuit symbol:



Ordering example:

Assembly 7631

R	0.45	- ...	- PYD	- EX
			Supplement	<a href="#">D 6010</a> , Table 5
			Seals	<a href="#">D 6010</a> , Table 4
			Versions	<a href="#">D 6010</a> , Table 3
			Delivery flow coding	<a href="#">"Table 3"</a>
			Basic type	<a href="#">"Table 1"</a>

Assembly 6010 - 6016

R	1.15 - 1.15 - 1.15	- ...	- PYD	- EX
			Supplement	<a href="#">D 6010</a> , Table 5
			Seals	<a href="#">D 6010</a> , Table 4
			Versions	<a href="#">D 6010</a> , Table 3
			Delivery flow coding	<a href="#">"Table 5"</a>
			Basic type	<a href="#">"Table 1"</a>

## 2.2 Pump types and combinations

**Table 1 Basic type**

Type	Description
R	Series, version with roller bearing
RG	Version with plain bearing (type RG not available for assembly 7631)

**NOTE**

- The pressure connection (PC) with the greatest flow rate has to be routed to P1.
- Multiple cylinders can be grouped to increase the flow rate. There are two ways to do this:
  - Simple group within a single cylinder radial, only possible for assemblies 7631, 6010, 6011, 6012.
  - Group of multiple complete cylinder radials, only possible for assemblies 6014, 6016.
- Greater pressure can be achieved by combining multiple pump elements of smaller diameter to a single group.
- To achieve a specific flow rate, use blanking plugs as necessary.

Example of a radial piston pump design

**Customer specifications:**

Number of pressure connections, required flow rates, pressures that may be required

- First, find the desired number of pressure connections in the pressure connections table.
- The sum of the desired flow rates supplies the radial piston pump's max. flow rate.
- Find the max. flow rate for connection to P1.
- You are now left with a choice of possible assemblies and layout for the grouped cylinders.
- "[Table 3 Delivery flow codings](#)" will now allow you to check feasibility based on the desired specifications. To check, find the required flow rates for the number of grouped cylinders per pressure connection and make sure that groups can be formed in the requested layout.

**Customer specifications:**

Pressure connections, 4.5 lpm (300 bar), 0.5 lpm (500 bar), 0.3 lpm (700 bar)

**Approach to solve:**

- Max. flow rate =  $(4.5 + 0.5 + 0.3) \text{ lpm} = 5.3 \text{ lpm}$
- Assembly 6011; cylinder layout 3-1-1
- 4.5 lpm cannot be realised → 4.3 lpm at 300 bar
- 0.5 lpm can be realised at 550 bar
- 0.3 lpm possible at 700 bar

Next, you will need to discuss with the customer whether and how realisation is feasible.

**NOTE**

For design reasons, each pump cylinder on assembly 7631 is routed outwards through its own pressure connection. Grouping the connections requires piping outside of the pump. This does not apply when combining 2 x 3 pump cylinders.



**Table 2 Pressure connections on assembly 7631**

Number of pressure connections (PC)	Max. flow rate (lpm) of assembly overall at 1450 min <sup>-1</sup> and 250 bar	Max. flow rate (lpm) at 1450 min <sup>-1</sup> and 250 bar for PC 1	Number of grouped cylinders	Number of full radials grouped	Assembly	Circuit symbol	Cylinder arrangement
2	0.9	0.45	--	--	7631		
2	2.7	1.35	3-3	1-1	7631		
3	1.35	0.45	--	--	7631		
4	1.8	0.45	--	--	7631		
5	2.25	0.45	--	--	7631		

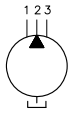
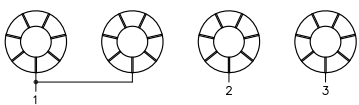
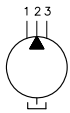
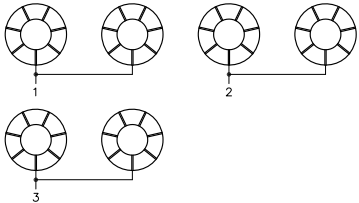
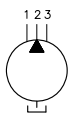
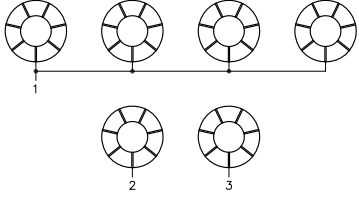
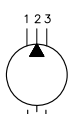
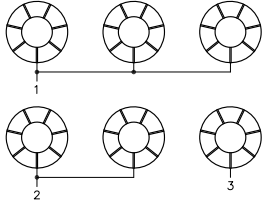
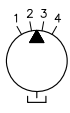
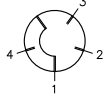
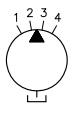
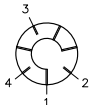
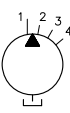
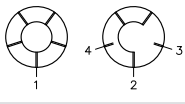
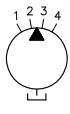
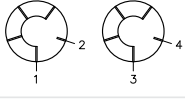
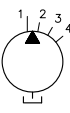
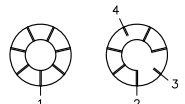
**Table 3 Delivery flow coding for assembly 7631**

Coding Delivery flow (lpm) at 1450 min <sup>-1</sup>	Geometric displacement V <sub>g</sub> (cm <sup>3</sup> /rev)	Pressure p <sub>max</sub> (bar)	Number of cylinder radials grouped x cylinders per radial	Number of pump elements	Pump element piston diameter (mm)
0.09	0.062	700	--	1	4
0.14	0.096	550	--	1	5
0.22	0.14	450	--	1	6
0.27	0.186	700	--	3	4
0.29	0.19	350	--	1	7
0.36	0.25	300	--	1	8
0.42	0.288	550	--	3	5
0.45	0.31	250	--	1	9
0.46	0.31	700	--	5	4
0.64	0.42	450	--	3	6
0.7	0.48	550	--	5	5
0.81	0.57	350	--	3	7
1.08	0.7	450	--	5	6
1.1	0.75	300	--	3	8
1.35	0.93	250	--	3	9
1.39	0.95	350	--	5	7
1.77	1.25	300	--	5	8
2.27	1.55	250	--	5	9


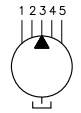
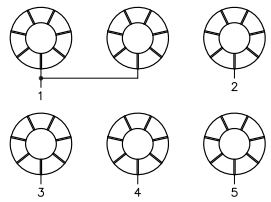

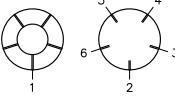

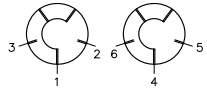


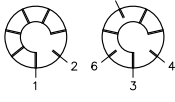

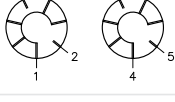

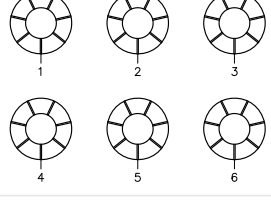

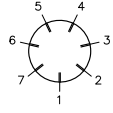
**Table 4 Pressure connections on assembly 6010 - 6016**

Number of pressure connections (PC)	Number of grouped cylinders	Number of full radials grouped	Assembly	Circuit symbol	Cylinder arrangement
2	1-1	--	6010		
2	2-1	--	6010		
2	4-1	--	6011		5 cylinders per radial 
2	6-1	--	6011		7 cylinders per radial 
2	5-5	1-1	6012		5 cylinders per radial 
2	7-7	1-1	6012		7 cylinders per radial 
2	10-10	2-2	6014		5 cylinders per radial 
2	15-5	3-1	6014		5 cylinders per radial 
2	14-14	2-2	6014		7 cylinders per radial 
2	21-7	3-1	6014		7 cylinders per radial 

Number of pressure connections (PC)	Number of grouped cylinders	Number of full radials grouped	Assembly	Circuit symbol	Cylinder arrangement
2	21-21	3-3	6016		7 cylinders per radial 
2	28-14	4-2	6016		7 cylinders per radial 
2	35-7	5-1	6016		7 cylinders per radial 
3	1-1-1	--	6010		
3	3-1-1	--	6011		5 cylinders per radial 
3	5-1-1	--	6011		7 cylinders per radial 
3	5-4-1	1	6012		5 cylinders per radial 
3	7-6-1	1	6012		7 cylinders per radial 
3	10-5-5	2-1-1	6014		5 cylinders per radial 

Number of pressure connections (PC)	Number of grouped cylinders	Number of full radials grouped	Assembly	Circuit symbol	Cylinder arrangement
3	14-7-7	2-1-1	6014		7 cylinders per radial 
3	14-14-14	2-2-2	6016		7 cylinders per radial 
3	28-7-7	4-1-1	6016		7 cylinders per radial 
3	21-14-7	3-2-1	6016		7 cylinders per radial 
4	2-1-1-1	--	6011		5 cylinders per radial 
4	4-1-1-1	--	6011		7 cylinders per radial 
4	5-3-1-1	1	6012		5 cylinders per radial 
4	4-1-4-1	--	6012		5 cylinders per radial 
4	7-5-1-1	1	6012		7 cylinders per radial 

Number of pressure connections (PC)	Number of grouped cylinders	Number of full radials grouped	Assembly	Circuit symbol	Cylinder arrangement
4	6-1-6-1	--	6012		7 cylinders per radial 
4	5-5-5-5	1-1-1-1	6014		5 cylinders per radial 
4	7-7-7-7	1-1-1-1	6014		7 cylinders per radial 
4	14-14-7-7	2-2-1-1	6016		7 cylinders per radial 
4	21-7-7-7	3-1-1-1	6016		7 cylinders per radial 
5	1-1-1-1-1	--	6011		5 cylinders per radial 
5	3-1-1-1-1	--	6011		7 cylinders per radial 
5	5-2-1-1-1	1	6012		5 cylinders per radial 
5	4-1-3-1-1	--	6012		5 cylinders per radial 
5	6-1-5-1-1	--	6012		7 cylinders per radial 

Number of pressure connections (PC)	Number of grouped cylinders	Number of full radials grouped	Assembly	Circuit symbol	Cylinder arrangement
5	7-4-1-1-1	1	6012		7 cylinders per radial 
5	14-7-7-7-7	2-1-1-1-1	6016		7 cylinders per radial 
6	5-1-1-1-1-1	1	6012		5 cylinders per radial 
6	3-1-1-3-1-1	--	6012		5 cylinders per radial 
6	7-3-1-1-1-1	1	6012		7 cylinders per radial 
6	6-1-4-1-1-1	--	6012		7 cylinders per radial 
6	5-1-1-5-1-1	--	6012		7 cylinders per radial 
6	7-7-7-7-7-7	1-1-1-1-1-1	6016		7 cylinders per radial 
7	1-1-1-1-1-1-1	--	6011		7 cylinders per radial 

Number of pressure connections (PC)	Number of grouped cylinders	Number of full radials grouped	Assembly	Circuit symbol	Cylinder arrangement
7	4-1-1-1-1-1-1	--	6012		5 cylinders per radial 
7	6-1-3-1-1-1-1	--	6012		7 cylinders per radial 
7	5-1-1-4-1-1-1	--	6012		7 cylinders per radial 
8	3-1-1-1-1-1-1-1	--	6012		5 cylinders per radial 
8	4-1-1-1-4-1-1-1	--	6012		7 cylinders per radial 
8	7-1-1-1-1-1-1-1	1	6012		7 cylinders per radial 
8	6-1-2-1-1-1-1-1	--	6012		7 cylinders per radial 
8	5-1-1-3-1-1-1-1	--	6012		7 cylinders per radial 
9	2-1-1-1-1-1-1-1-1	--	6012		5 cylinders per radial 
9	6-1-1-1-1-1-1-1-1	--	6012		7 cylinders per radial 

Number of pressure connections (PC)	Number of grouped cylinders	Number of full radials grouped	Assembly	Circuit symbol	Cylinder arrangement
10	1-1-1-1-1-1-1-1-1-1	--	6012		5 cylinders per radial 
10	5-1-1-1-1-1-1-1-1-1	--	6012		7 cylinders per radial 
10	4-1-1-1-2-1-1-1-1-1	--	6012		7 cylinders per radial 
10	3-1-1-1-1-3-1-1-1-1	--	6012		7 cylinders per radial 
11	4-1-1-1-1-1-1-1-1-1-1	--	6012		7 cylinders per radial 
11	3-1-1-1-1-2-1-1-1-1-1	--	6012		7 cylinders per radial 
12	3-1-1-1-1-1-1-1-1-1-1-1	--	6012		7 cylinders per radial 
13	2-1-1-1-1-1-1-1-1-1-1-1-1	--	6012		7 cylinders per radial 
14	1-1-1-1-1-1-1-1-1-1-1-1-1-1	--	6012		7 cylinders per radial 



**Table 5 Delivery flow coding for assembly 6010 - 6016**

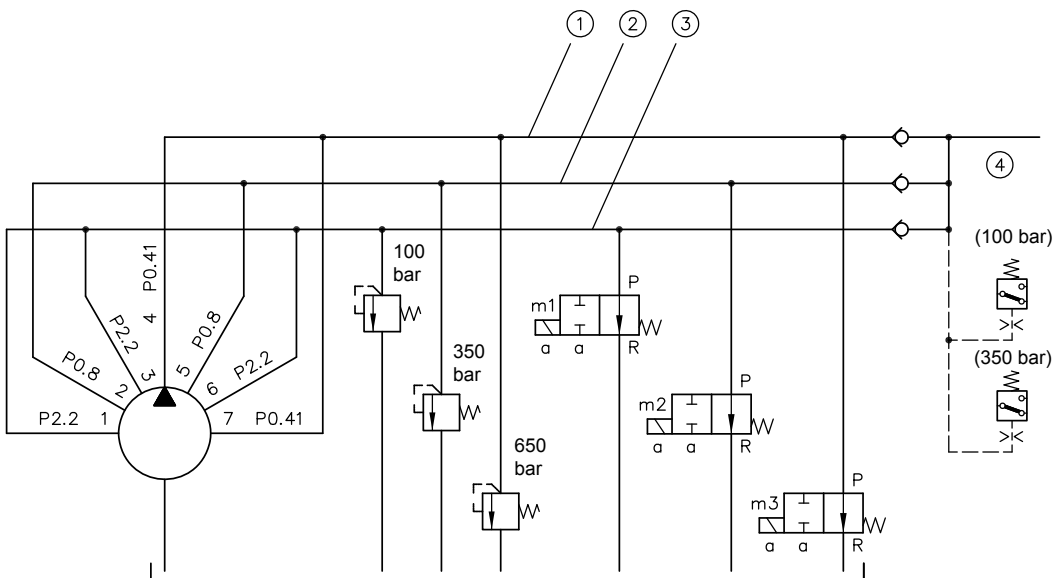
Coding Delivery flow (lpm) at 1450 min <sup>-1</sup>	Geometric displace- ment V <sub>g</sub> (cm <sup>3</sup> /rev)	Pressure p <sub>max</sub> (bar)	Number of grouped cylinders per pressure connection	Number of cylinder radials grouped x cylinders per radial	Pump element piston diameter (mm)
0.3	0.21	700	1	--	6
0.41	0.29	600	1	--	7
0.5	0.38	550	1	--	8
0.6	0.42	700	2	--	6
0.8	0.6	450	1	--	10
0.83	0.58	600	2	--	7
0.9	0.63	700	3	--	6
1	0.76	550	2	--	8
1.15	0.84	700	4	--	6
1.2	0.86	350	1	--	12
1.25	0.87	600	3	--	7
1.4	1.05	700	5	1 x 5	6
1.45	1.01	300	1	--	13
1.5	1.14	550	3	--	8
1.6	1.18	450	2	--	10
1.65	1.16	600	4	--	7
1.7	1.17	250	1	--	14
1.8	1.26	700	6	--	6
1.9	1.34	200	1	--	15
2.08	1.45	600	5	1 x 5	7
2.1	1.47	700	7	1 x 7	6
2.15	1.52	550	4	--	8
2.2	1.53	160	1	--	16
2.4	1.68	350	2	--	12
2.45	1.74	600	6	--	7
2.5	1.77	450	3	--	10
2.6	1.9	550	5	1 x 5	8
2.7	2.1	700	10	2 x 5	6
2.8	2	300	2	--	13
2.9	2.03	600	7	1 x 7	7
3.2	2.28	550	6	--	8
3.3	2.3	250	2	--	14
3.35	2.36	450	4	--	10
3.6	2.52	350	3	--	12
3.7	2.66	550	7	1 x 7	8
3.8	2.64	200	2	--	15
4	2.94	700	14	2 x 7	6
4.15	2.9	600	10	2 x 5	7
4.2	2.95	450	5	1 x 5	10

Coding Delivery flow (lpm) at 1450 min <sup>-1</sup>	Geometric displace- ment V <sub>g</sub> (cm <sup>3</sup> /rev)	Pressure p <sub>max</sub> (bar)	Number of grouped cylinders per pressure connection	Number of cylinder radials grouped x cylinders per radial	Pump element piston diameter (mm)
4.3	3	300	3	--	13
4.4	3.06	160	2	--	16
4.6	3.15	700	15	3 x 5	6
4.8	3.36	350	4	--	12
5	3.54	450	6	--	10
5.1	3.45	250	3	--	14
5.3	3.8	550	10	2 x 5	8
5.6	3.96	200	3	--	15
5.7	4	300	4	--	13
5.8	4.13	450	7	1 x 7	10
5.85	4.06	600	14	2 x 7	7
5.95	4.41	700	21	3 x 7	6
6	4.2	350	5	1 x 5	12
6.2	4.35	600	15	3 x 5	7
6.5	4.59	160	3	--	16
6.7	4.6	250	4	--	14
7	5	300	5	1 x 5	13
7.2	5.04	350	6	--	12
7.4	5.32	550	14	2 x 7	8
7.7	5.28	200	4	--	15
8	5.88	700	28	4 x 7	6
8.2	5.9	450	10	2 x 5	10
8.25	5.7	550	15	3 x 5	8
8.3	5.75	250	5	1 x 5	14
8.4	5.88	350	7	1 x 7	12
8.6	6	300	6	--	13
8.7	6.12	160	4	--	16
8.75	6.09	600	21	3 x 7	7
9.5	6.6	200	5	1 x 5	15
9.8	7	300	7	1 x 7	13
9.9	6.9	250	6	--	14
10.6	7.35	700	35	5 x 7	6
10.9	7.65	160	5	1 x 5	16
11.2	7.98	550	21	3 x 7	8
11.5	7.92	200	6	--	15
11.6	8.26	450	14	2 x 7	10
11.65	8.12	600	28	4 x 7	7
11.8	8.05	250	7	1 x 7	14
12	8.4	350	10	2 x 5	12
13	8.85	450	15	3 x 5	10
13.1	9.18	160	6	--	16

Coding Delivery flow (lpm) at 1450 min <sup>-1</sup>	Geometric displace- ment V <sub>g</sub> (cm <sup>3</sup> /rev)	Pressure p <sub>max</sub> (bar)	Number of grouped cylinders per pressure connection	Number of cylinder radials grouped x cylinders per radial	Pump element piston diameter (mm)
13.3	9.24	200	7	1 x 7	15
14.2	10	300	10	2 x 5	13
14.55	10.15	600	35	5 x 7	7
15	10.64	550	28	4 x 7	8
15.3	10.71	160	7	1 x 7	16
16.8	11.5	250	10	2 x 5	14
17	11.76	350	14	2 x 7	12
17.3	12.39	450	21	3 x 7	10
18.3	13.3	550	35	5 x 7	8
18.8	12.6	350	15	3 x 5	12
19.3	13.2	200	10	2 x 5	15
20	14	300	14	2 x 7	13
21.7	15.3	160	10	2 x 5	16
22.5	15	300	15	3 x 5	13
23	16.52	450	28	4 x 7	10
23.5	16.1	250	14	2 x 7	14
25.2	17.25	250	15	3 x 5	14
25.5	17.64	350	21	3 x 7	12
26.5	18.48	200	14	2 x 7	15
28.5	19.8	200	15	3 x 5	15
28.8	20.65	450	35	5 x 7	10
29.9	21	300	21	3 x 7	13
30.4	21.42	160	14	2 x 7	16
32.6	22.95	160	15	3 x 5	16
34	23.52	350	28	4 x 7	12
35.3	24.15	250	21	3 x 7	14
39.8	27.72	200	21	3 x 7	15
40	28	300	28	4 x 7	13
42.5	29.4	350	35	5 x 7	12
45.6	32.13	160	21	3 x 7	16
47	32.2	250	28	4 x 7	14
50	35	300	35	5 x 7	13
53	36.96	200	28	4 x 7	15
58.4	40.25	250	35	5 x 7	14
60.8	42.84	160	28	4 x 7	16
66.7	46.2	200	35	5 x 7	15
76	53.55	160	35	5 x 7	16

## 2.3 Pressure connection characteristics

When dividing a cylinder radial into separate connections (assembly 7631, 6010, 6011 and 6012) or cylinder groups (assembly 6010, 6011 and 6012), their flow rates will display a certain degree of pulsing. At customary drive speeds around  $1450 \text{ min}^{-1}$  these will generally be negligible. For the cylinder groups comprising 5- or 7-cylinder pumps, the associated pump cylinders have already been internally grouped in such a way as to leave the remaining single cylinders distributed as widely as possible between them. Refer to the linkage diagram for assemblies 6011 or 6012 in [Chapter 2.2](#). This creates more favourable harmonics, with almost no pulsing. For pump cylinders routed outwards separately, when combining them into groups outside of the pump, choose the delivery flow coding sequence in a way that ensures a corresponding distribution. The following example shows a pump for assembly 6011 with seven connections grouped externally to three separate lines with different flow rates and pressures.

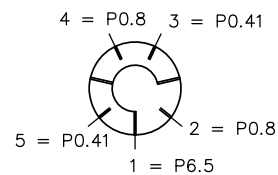


- 1 650 bar - line 0.83 lpm
- 2 350 bar - line 1.6 lpm
- 3 100 bar - line 6.5 lpm
- 4 To the consumer

### Example:

R 2.2 - 0.8 - 2.2 - 0.41 - 0.8 - 2.2 - 0.41

In practice in such a case, you would use a pump  
R 6.5 - 0.8 - 0.41 - 0.8 - 0.41 and group the three  
pump cylinders with coding 2.2 internally.



## 2.4 Motor

Power consumption:

Precise calculation would take a comparatively long time. It is sufficient to use approximated values according to the following formula. The reference value for required drive power results from calculating and adding together the power required by the pump cylinders or cylinder groups simultaneously acting counter to the respectively associated maximum pressure. If the pumps for assemblies 7631, 6010, 6011 and 6012 still have gaps because there are pump cylinders simultaneously delivering without pressure, the total power calculated needs to be multiplied by a correction factor, thus taking into account the uniformity coefficient. It may be necessary to recalculate several times for different load cycles. The greatest power value calculated should then be applied to choose the motor rating.

$$P_{\text{req}} = (P_{Z1} + P_{Z2} + \dots) \cdot k \quad \text{Total required power in kW}$$

where:

$$P_Z = \frac{p_Z \cdot Q_Z}{600 \cdot \eta_Z} = (\text{kW}) \text{ required power of single cylinder or overall cylinder group}$$

$p_Z$  (bar) = max. operating pressure for cylinder group

$Q_Z$  (lpm) = flow rate of cylinder group = delivery flow coding ["Table 3"](#) or ["Table 5"](#)

$\eta_Z$  (-) =  $\approx 0.85$  mechanical/hydraulic efficiency of cylinder group

$k$  (-) = correction factor, if required (see ["Table 6"](#))

The correction factor is used to take into account how pulsing affects the required power. The lower the expected pulsation, the lower the correction factor you need ( $k = 1$ ). The less favourable the radial piston pump's layout, the higher the correction factor needs to be. Required power is highest at a correction factor of  $k = 3$ . ["Table 6"](#) shows examples of the correction factor to choose.

**Table 6 Correction factors**

Pump type	2-cylinder pump		3-cylinder pump		5-cylinder pump							7-cylinder pump																		
Cylinder	a	●	●	●	●	●	●	●	●	●	●	●	●	●	●	●	●	●	●	●	●	●	●	●	●	●	●	●	●	●
	b	●	●	●	●																									
	c																													
	d																													
	e																													
	f																													
	g																													
Correction factor $k \approx$	3	1.5	3	1.5	1	3	1.5	1.3	1	1.6	1.9	3	1.7	1.5	1.3	1.2	1	3	1.6	1.5	1.2	1.3	1.5							

with ● = cylinder delivering hydraulic oil  
( $p = 0$  up to around 10% of ●)

without ● = unloaded cylinder

### Calculation example:

Given: Circuit example from section 2.3 with 7-cylinder pump assembly 6011 (R 6.5-0.8-0.41-0.8-0.41)

#### Case 1:

All three pressure circuits operate jointly up to around 100 bar  
(Switching position  $m_1 + m_3 = a$ )

$$P_{6.5} \dots P_{Z1} = \frac{100 \cdot 6.5}{600 \cdot 0.85} = 1.27 \text{ kW}$$

$$2 \times P_{0.8} \dots P_{Z2} = \frac{100 \cdot 1.6}{600 \cdot 0.85} = 0.32 \text{ kW}$$

$$2 \times P_{0.41} \dots P_{Z3} = \frac{100 \cdot 0.83}{600 \cdot 0.85} = 0.16 \text{ kW}$$

Because all pump cylinders are pumping upstream,  $k = 1$

$$P_{\text{req } 1} = (1.27 + 0.32 + 0.16) \cdot 1 = 1.75 \text{ kW}$$

#### Case 2:

P 6.5-circuit set to circulation ( $m_1 = 0$ ); remaining pressure ranges up to around 350 bar

$$P_{6.5} \dots P_{Z1} = 0$$

$$2 \times P_{0.8} \dots P_{Z2} = \frac{100 \cdot 1.6}{600 \cdot 0.85} = 0.32 \text{ kW}$$

$$2 \times P_{0.41} \dots P_{Z3} = \frac{100 \cdot 0.83}{600 \cdot 0.85} = 0.16 \text{ kW}$$

Load gaps for P 6.5 match a correction factor of  $k \approx 1.2$

$$P_{\text{req } 2} = (1.10 + 0.57) \cdot 1.2 = 2.00 \text{ kW}$$

#### Case 3:

P 6.5- and 2 x P 0.8-circuits set to circulation ( $m_1 + m_2 = 0$ )

2 x P 0.41-circuits up to 650 bar

$$P_{6.5} \text{ and } P_{1.6} = P_{Z1} \text{ and } P_{Z2} = 0$$

$$2 \times P_{0.41} \dots P_{Z3} = \frac{650 \cdot 0.83}{600 \cdot 0.85} = 1.06 \text{ kW}$$

Load gaps for P 6.5 and 2 x P 0.8 match a correction factor of  $k \approx 1.5$

$$P_{\text{req } 3} = 1.06 \cdot 1.5 = 1.59 \text{ kW}$$

#### Case 4:

Motor load at startup acting against pressure-limiting valves (malfunction calculation for failure of  $m_1$ ,  $m_2$  and  $m_3$ )

$$P_{6.5} \dots P_{Z1} = 1.27 \text{ kW (} P_{Z1} \text{ from case 1)}$$

$$2 \times P_{0.8} \dots P_{Z2} = 1.10 \text{ kW (} P_{Z2} \text{ from case 2)}$$

$$2 \times P_{0.41} \dots P_{Z3} = 1.06 \text{ kW (} P_{Z3} \text{ from case 3)}$$

All pump cylinders pumping upstream,  $k = 1$

$$P_{\text{req } 4} = (1.27 + 1.10 + 1.06) \cdot 1 = 3.43 \text{ kW}$$

Choice based on load cases 1 to 3 would be a 2.2-kW motor. The 3.4 kW calculated for case 4 equate to roughly 55% overload. Current consumption will then be roughly 60% above nominal current. If such a malfunction were to occur and not be noticed, a bimetallic strip trigger configured for nominal current would in cold state trip after around 1 to 1.5 minutes. If the load interval with the greatest required power (case 2 with 2.00 kW) permits overloading of the next-lower nominal motor power, in this example 1.5 kW at 31% overload, a corresponding motor could also be chosen. This assumes that durations  $t_1, t_2, t_3 \dots$  for  $P_{req\ 1}, P_{req\ 2} \dots$  etc. of the separate load intervals, including any idle or shutdown times (S 6 or S 3 operation), produce a mean load equivalent to or lower than that motor's nominal power. This mean load can be estimated over the total duration  $T = t_1 + t_2 + t_3 + \dots$  of one of the successive load cycles as

$$P_{erfm} = \sqrt{\frac{1}{T} (P_{erf1}^2 \cdot t_1 + P_{erf2}^2 \cdot t_2 + \dots)}$$

If, for example, the three load intervals 1.75 kW ( $P_{req\ 1}$ ) with  $t_1 = 10$  s, 2.00 kW ( $P_{req\ 2}$ ) with  $t_2 = 12$  s and 1.59 kW ( $P_{req\ 3}$ ) with 8 s run successively without idle or shutdown times ( $T = 20$  s), this would indicate the originally chosen 2.2-kW motor

$$P_{erfm} = \sqrt{\frac{1}{20} (1.75^2 \cdot 10 + 2.00^2 \cdot 12 + 1.59^2 \cdot 8)} = 2.22 \text{ kW}$$

If there were to be an idle time  $t_i$  before the next load cycle (S 6 operation), it would have to be approx. 22 to 25 s to produce  $P_{req\ m} \approx 1.5$  kW.

## General information

**i** NOTE

The following conditions may result in efficiency losses:

- Viscosities > 500 mm<sup>2</sup>/s and < 10 mm<sup>2</sup>/s
- Operating pressures < 20 bar
- Rotation speeds > 2000 min<sup>-1</sup>; especially with a small piston diameter

<b>Designation</b>	Radial piston pump, constant pump						
<b>Mounting position</b>	Any angle between horizontal and vertical <a href="#">D 6010 H</a> , Section 5						
<b>Attachment</b>	On the front side via the flange						
<b>Line connection</b>	Pipe thread ISO 228-1, for port sizes see dimension diagrams <a href="#">Chapter 4, "Dimensions"</a>						
<b>Drive and rotation direction</b>	Via flex-coupling, rotation direction as desired						
<b>Flow direction</b>	Determined by suction and pressure connection, independent of the rotation direction						
<b>Speed range</b>	<p>Continuous:</p> <p>R = 100 ... 2000 min<sup>-1</sup>            RG = 1000 ... 2000 min<sup>-1</sup></p> <p>2800 min<sup>-1</sup> admissible for brief periods, please note in this connection that bell housings, flanges, couplings, etc. (<a href="#">D 6010 H</a>) are only available for industrial standard motor sizes 71 to 200 L. The associated motor power acc. to DIN 42677 (Table 2) applies to the standard range. If the motor is used under increased speed conditions, a reduction of the maximum pump pressure should be expected, see <a href="#">Chapter 2.4, "Motor"</a>.</p>						
<b>Hydraulic fluid</b>	<p>Hydraulic oil: in accordance with (part 1 to 3) 10 ... 68 mm<sup>2</sup>/s at 40°C; ISO VG 10 to 68 in accordance with DIN ISO 3448</p> <p>Optimum operating viscosity: approx. 10 ... 500 mm<sup>2</sup>/s</p> <p>Viscosity limits (start viscosity):</p> <table style="width: 100%; border: none;"> <tr> <td style="width: 30%;">Type R 0.18 ... R 2.27:</td> <td style="width: 30%;">min. approx. 4; max. approx. 800 mm<sup>2</sup>/s</td> <td style="width: 40%;"></td> </tr> <tr> <td>R 0.3 ... R 91.2:</td> <td>min. approx. 4; max. approx. 1500 mm<sup>2</sup>/s</td> <td></td> </tr> </table> <p>Also suitable for biologically degradable pressure fluids type HEPG (polyalkylene glycol) and HEES (synthetic ester) at operating temperatures up to approx. +70°C.            Version type R..-HFA is also suitable for water based pressure fluids. Due to the limited lubricity of the hydraulic fluid, the pump should only be operated in standby mode in order to preserve a reasonable service life. The max. operating pressure should not exceed approx. 75% of the p<sub>max</sub> indicated in Table 1b.</p>	Type R 0.18 ... R 2.27:	min. approx. 4; max. approx. 800 mm <sup>2</sup> /s		R 0.3 ... R 91.2:	min. approx. 4; max. approx. 1500 mm <sup>2</sup> /s	
Type R 0.18 ... R 2.27:	min. approx. 4; max. approx. 800 mm <sup>2</sup> /s						
R 0.3 ... R 91.2:	min. approx. 4; max. approx. 1500 mm <sup>2</sup> /s						
<b>Cleanliness level</b>	Recommended cleanliness in accordance with ISO 4406, see oil recommendation <a href="#">D 5488/1</a>						
<b>Temperatures</b>	<p>Ambient temperature: approx. -40 ... +80°C,            Oil temperature: -25 ... +80°C, pay attention to the viscosity range.            Start temperature: down to -40°C is permissible (observe start viscosities!), as long as the steady-state temperature is at least 20K higher during subsequent operation.            Biologically degradable hydraulic fluids: note manufacturer specifications. With consideration for the seal compatibility, not above +70°C.</p>						



## Pressure and flow rate

### Operating pressure

Pressure side (outlet): Depending on piston  $\varnothing$ , see [Chapter 2, "Available versions, main data"](#)

Suction side: - 0.3 bar ... + 1 bar (approx. 0.7 bar abs. ... approx. 2 bar abs.)  
+ 2 bar (3 bar abs.) with type R(G) ... - A,  
see [D 6010](#) Section 5.2.2

### Flow rate

see ["Table 3"](#) and ["Table 5"](#)

Reference value depending on rotation speed:

$$Q_{Pu} = V_g n \cdot \eta_{vol} \cdot 10^{-3} \text{ lpm}$$

where:

$V_g$ in $\text{cm}^3/\text{rev}$	Geometric displacement <a href="#">"Table 3"</a> and <a href="#">"Table 5"</a>
$n$ in $\text{min}^{-1}$	Rotation speed
$\eta_{vol} \approx 0.98$	Volumetric efficiency

## Weight

see [D 6010](#) Section 3 Parameters

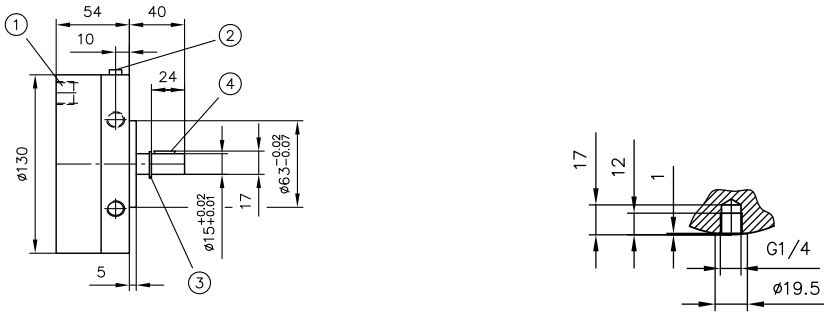
# 4

## Dimensions

All dimensions in mm, subject to change.

### 4.1 Assembly 7631

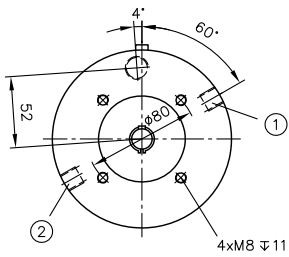
The pressure connections (P) are arranged radially around the pump diameter.



- 1 Suction port G 3/8
- 2 Bleed screw M6
- 3 Retaining ring A15 DIN 471
- 4 Wedge width 5

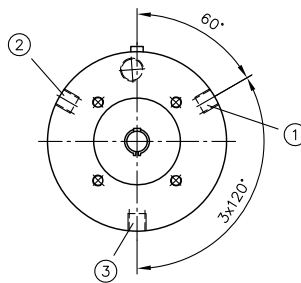
#### 1-radial pump

2 cylinders:

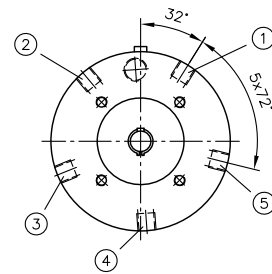


- 1 Pressure connection P1 G 1/4
- 2 Pressure connection P2 G 1/4
- 3 Pressure connection P3 G 1/4
- 4 Pressure connection P4 G 1/4
- 5 Pressure connection P5 G 1/4

3 cylinders:

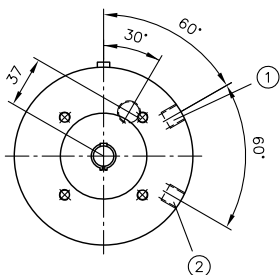


5 cylinders:



#### 2-radial pump

6 cylinders:



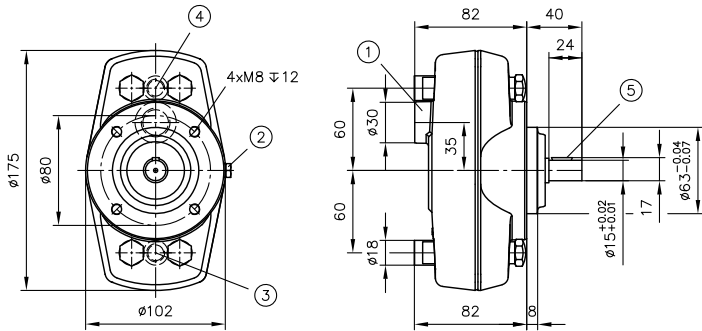
- 1 Pressure connection P1 G 1/4
- 2 Pressure connection P2 G 1/4

## 4.2 Assembly 6010

### 1-radial pump

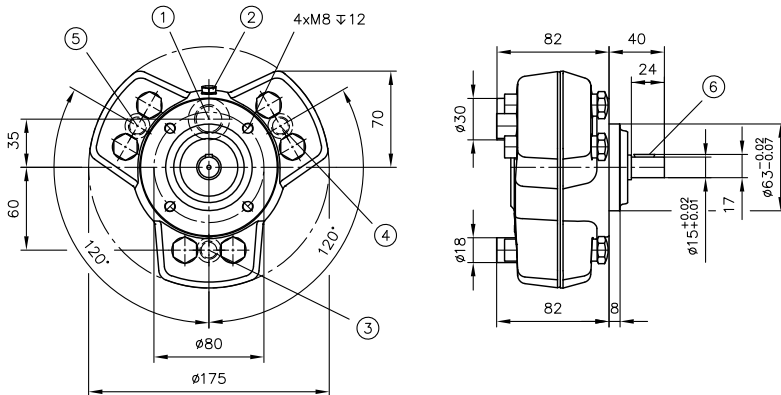
The pressure connections (P) are located on the suction side.

2 cylinders:



- 1 Suction port G 1/2
- 2 Bleed screw M6
- 3 Pressure connection P1 G 1/4
- 4 Pressure connection P2 G 1/4
- 5 Wedge width 5

3 cylinders:

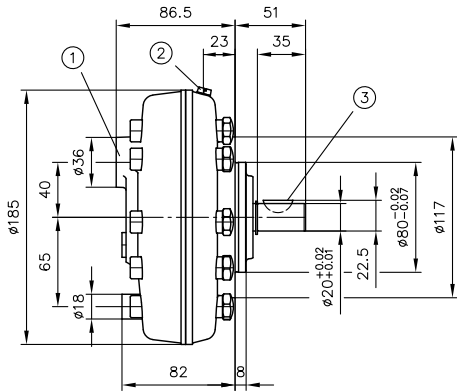


- 1 Suction port G 1/2
- 2 Bleed screw M6
- 3 Pressure connection P1 G 1/4
- 4 Pressure connection P2 G 1/4
- 5 Pressure connection P3 G 1/4
- 6 Wedge width 5

## 4.3 Assembly 6011

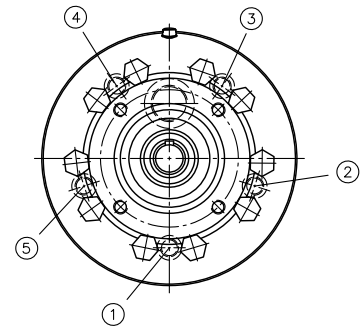
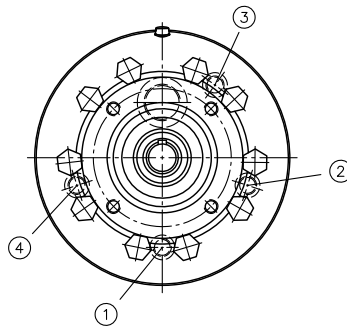
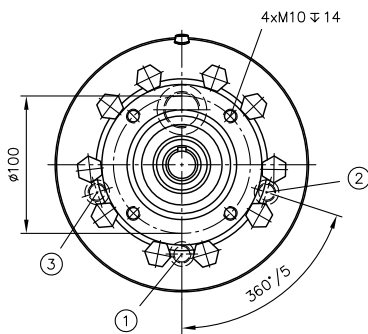
### 1-radial pump

The pressure connections are located on the suction side.



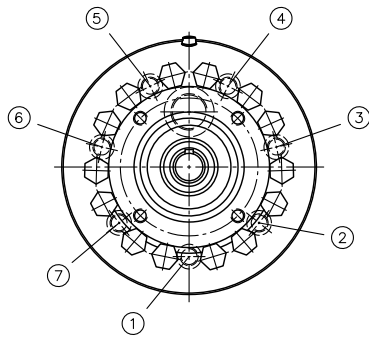
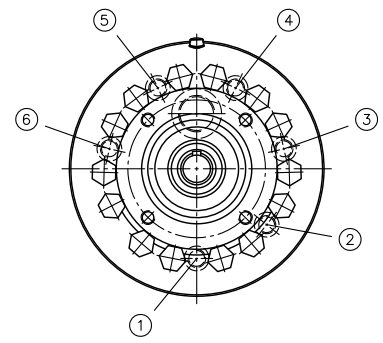
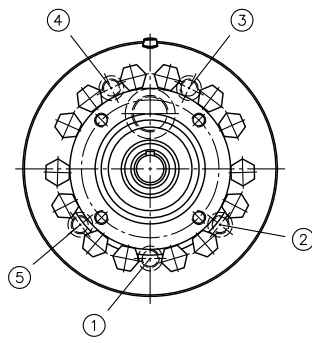
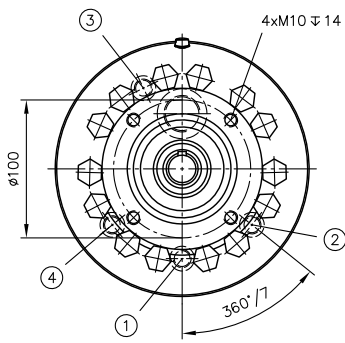
- 1 Suction port G 3/4
- 2 Bleed screw M6
- 3 Wedge width 6

5 cylinders:



- 1 Pressure connection P1 G 1/4
- 2 Pressure connection P2 G 1/4
- 3 Pressure connection P3 G 1/4
- 4 Pressure connection P4 G 1/4
- 5 Pressure connection P5 G 1/4

7 cylinders:



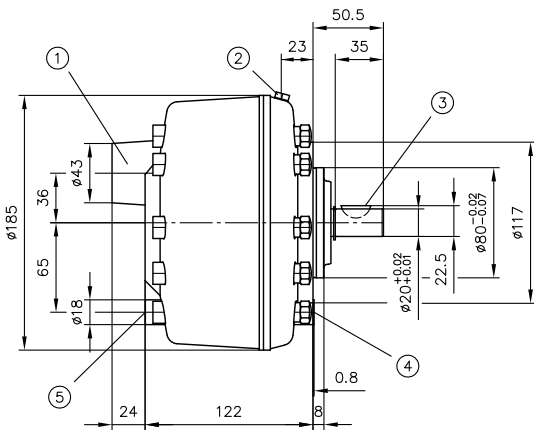
- 1 Pressure connection P1 G 1/4
- 2 Pressure connection P2 G 1/4
- 3 Pressure connection P3 G 1/4
- 4 Pressure connection P4 G 1/4
- 5 Pressure connection P5 G 1/4
- 6 Pressure connection P6 G 1/4
- 7 Pressure connection P7 G 1/4

## 4.4 Assembly 6012

### 2-radial pump

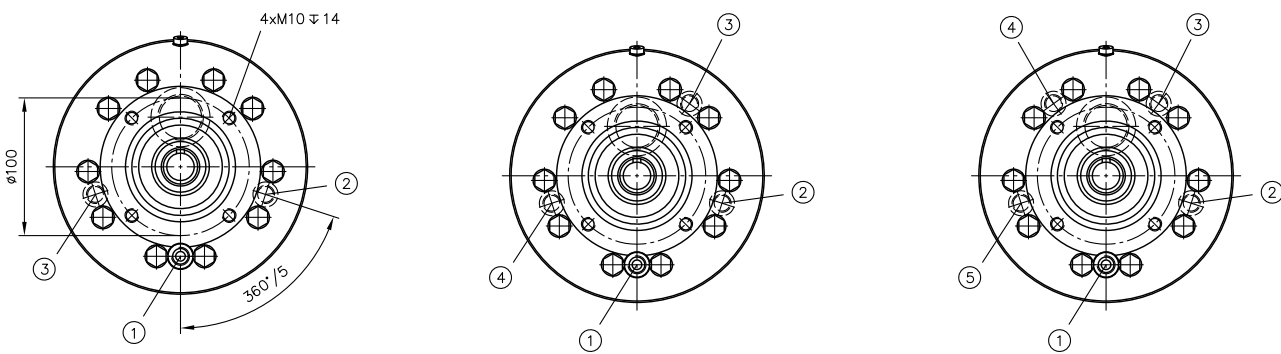
Pressure outlets discharging from cylinder radial 1 are located on the suction side.  
 Pressure outlets discharging from cylinder radial 2 are arranged on the shaft side.

**! NOTE**  
 Special cases (layout with two divided cylinder radials) have not been included here due to constraints of space. The pressure connections' dimensions are identical to those of the standard version.



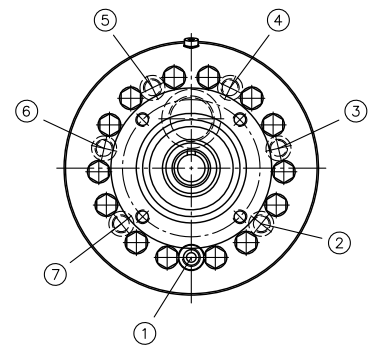
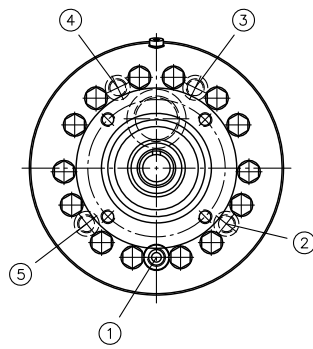
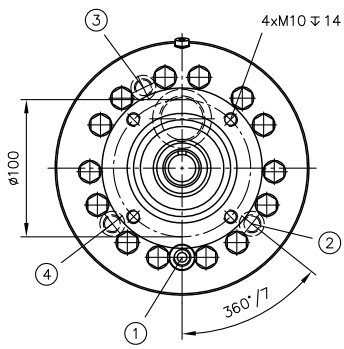
- 1 Suction port G 1
- 2 Bleed screw M6
- 3 Wedge width 6
- 4 Pressure connection P1 G 1/4
- 5 Pressure connection P2 G 1/4

5 cylinders:



- 1 Pressure connection P1(2) G 1/4
- 2 Pressure connection P3 G 1/4
- 3 Pressure connection P4 G 1/4
- 4 Pressure connection P5 G 1/4
- 5 Pressure connection P6 G 1/4

7 cylinders:

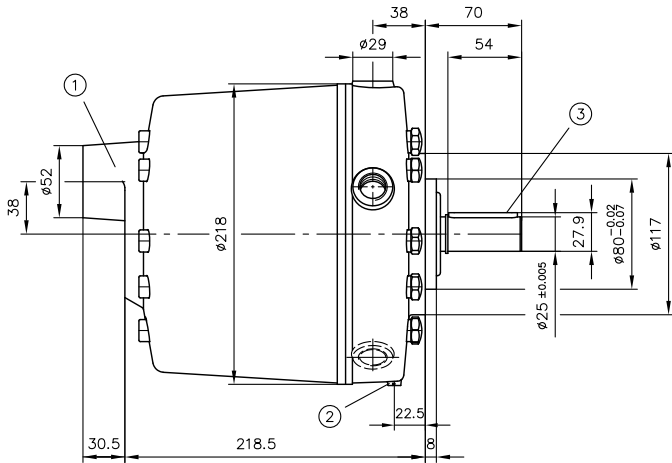


- 1 Pressure connection P1(2) G 1/4
- 2 Pressure connection P3 G 1/4
- 3 Pressure connection P4 G 1/4
- 4 Pressure connection P5 G 1/4
- 5 Pressure connection P6 G 1/4
- 6 Pressure connection P7 G 1/4
- 7 Pressure connection P8 G 1/4

## 4.5 Assembly 6014

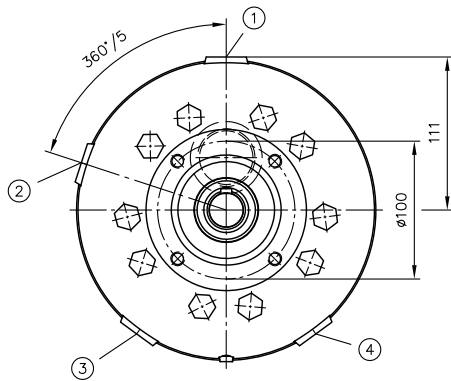
### 4-radial pump

The pressure connections are arranged radially around the pump diameter.  
Control ports are arranged on the suction side ([D 6010 S](#)).



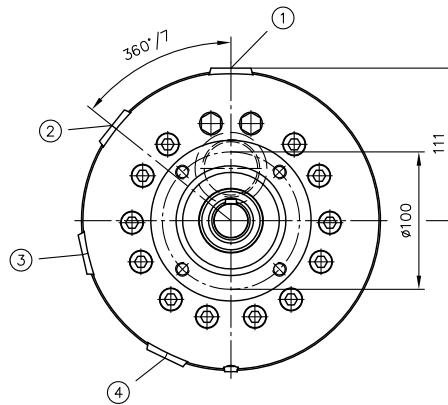
- 1 Suction port G 1 1/4
- 2 Bleed screw M6
- 3 Wedge width 8

5 cylinders:



- 1 Pressure connection P1 G 1/2
- 2 Pressure connection P2 G 1/2
- 3 Pressure connection P3 G 1/2
- 4 Pressure connection P4 G 1/2

7 cylinders:



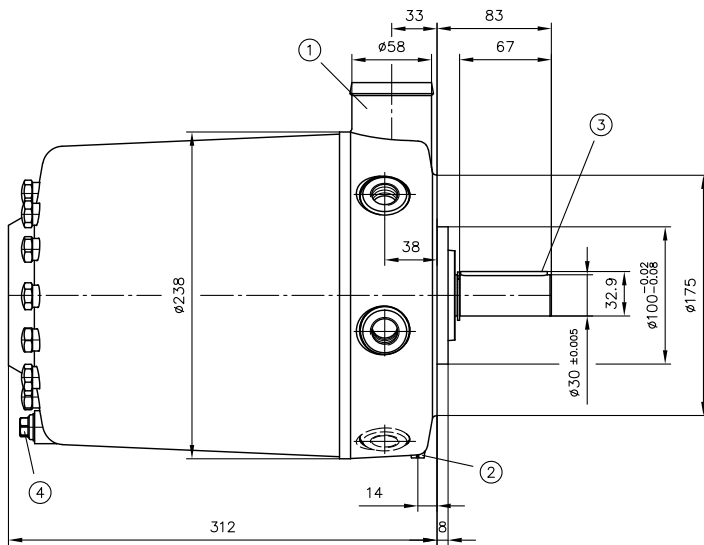
- 1 Pressure connection P1 G 1/2
- 2 Pressure connection P2 G 1/2
- 3 Pressure connection P3 G 1/2
- 4 Pressure connection P4 G 1/2



## 4.6 Assembly 6016

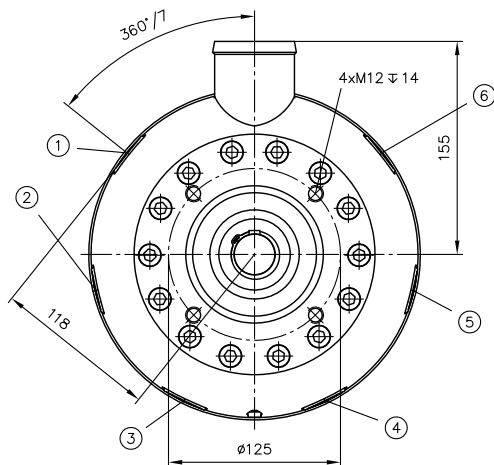
### 6-radial pump

The pressure connections are arranged radially around the pump diameter.  
Control ports are arranged on the suction side ([D 6010 S](#)).



- 1 Suction port G 1 1/2
- 2 Bleed screw M6
- 3 Wedge width 8
- 4 Oil drain screw G 1/4

7 cylinders:



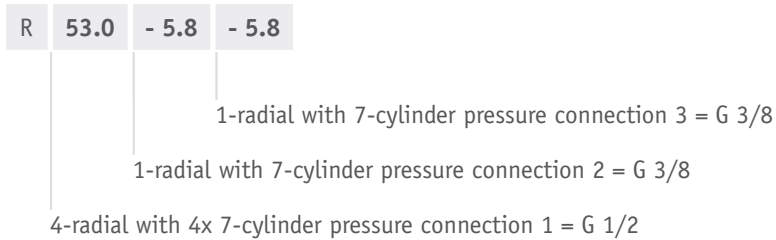
- 1 Pressure connection P1
- 2 Pressure connection P2
- 3 Pressure connection P3
- 4 Pressure connection P4
- 5 Pressure connection P5
- 6 Pressure connection P6

For pressure connection size, refer to ["Table 7"](#)

### Pressure connection port size:

The port size for the pressure connections is generally defined by the cylinder group's delivery flow coding (see ["Table 7"](#)). Pressure connection position is defined by the sequence of delivery flow codings in the order coding (see also ["Table 3"](#) and ["Table 5"](#)).

#### Example:



**Table 7 Pressure connection port size**

Number of cylinder radials grouped x number of cylinders per radial	Delivery flow coding							Ports (ISO 228-1)
	2.1	3.7	5.8	8.4	9.8	11.8	13.3	
1 x 7	2.1	3.7	5.8	8.4	9.8	11.8	13.3	G 3/8
2 x 7	4.0	7.4	11.6	17.0	20.0	23.5	26.5	
3 x 7	5.95	11.2	17.3	25.5	29.9	35.3	39.8	G 1/2
4 x 7	8.0	15.0	23.0	34.0	40.0	47.0	53.0	
5 x 7	10.6	18.3	28.8	42.5	50.0	58.4	66.7	G 3/4

### 5.1 Intended use

This pump is intended exclusively for use in hydraulic applications (fluid technology).

The user must observe the safety measures and warnings in this documentation.

#### Essential requirements for the product to function correctly and safely:

- All information in this documentation must be observed. This applies in particular to all safety measures and warnings.
- The product must only be assembled and put into operation by qualified personnel.
- The product must only be operated within the specified technical parameters. The technical parameters are described in detail in this documentation.
- All components must be suitable for the operating conditions in the event of application in an assembly.
- The operating and maintenance manual of the components, assemblies and the specific complete system must also always be observed.

If the product can no longer be operated safely:

1. Remove the product from operation and mark it accordingly.
- ✓ It is then not permitted to continue using or operating the product.

### 5.2 Assembly information

The product must only be installed in the complete system with standard and compliant connection components (screw fittings, hoses, pipes, fixtures etc.).

The product must be shut down correctly prior to dismantling (in particular in combination with hydraulic accumulators).

When both setting up the component as a motor pump outside an oil tank and installing it in an oil tank as a hydraulic power pack, care must be taken to ensure that the pump remains below the oil level at all times, even when the oil has been pre-filled before use. The housing shell forms a sealed space around the pump cylinders, which are arranged in a star configuration. This space can only be vented effectively when the pump is submerged as described during or after filling. For details on installation, venting and commissioning, see [D 6010 H](#), Section 5.



#### **DANGER**

#### **Risk to life caused by sudden movement of the hydraulic drives when dismantled incorrectly!**

Risk of serious injury or death.

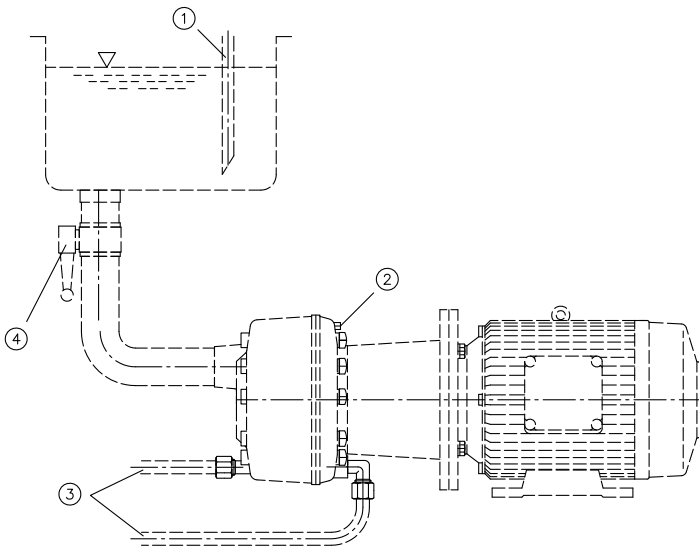
- Depressurise the hydraulic system.
- Perform safety measures in preparation for maintenance.

#### 5.2.1 Venting and commissioning

When commissioning the pump for the first time and after each oil change, bleed the pumps to prevent problems with the suction and air from entering the loads. See also operating instructions [B 6010](#).

## 5.2.2 Pump positioned outside of oil tank

The pump should always be arranged at a level lower than the lowest-possible oil level in the tank. It can be placed directly below the tank using a vertical downpipe suction line or to the side with a suction line rising gently towards the tank. Loosen the bleed screw after filling the oil tank (do not unscrew) and wait until oil leaks out. Then tighten the screw and let the pump operate for a short time with pressure-free circulation, if the control allows for this. Failing this, reset the pressure-limiting valve to pressure value zero and allow the pump to operate with pressure-free circulation above here. Next operate all the functions of the hydraulic system a few times without load, if necessary with the pressure-limiting valve put back, until they move smoothly and without hesitation. Raise pressure-limiting valve to the set point (monitor the pressure gauge).



- 1 Return line
- 2 Bleed screw
- 3 Pressure line
- 4 Shut-off valve

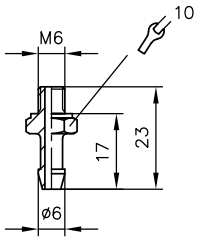
## 5.2.3 Installation in oil tank

Refer to publication [D 6010 DB](#).

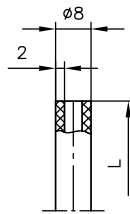
On tanks and tank cover plates not supplied by us, replace the bleed screw on the pump with a connection nipple according to drawing 6020 070 and add a bleed point in the cover plate according to the drawing below. Then connect these two connection nipples using an oil-resistant hose (8 x 2).

## 5.2.4 Available bleeding parts

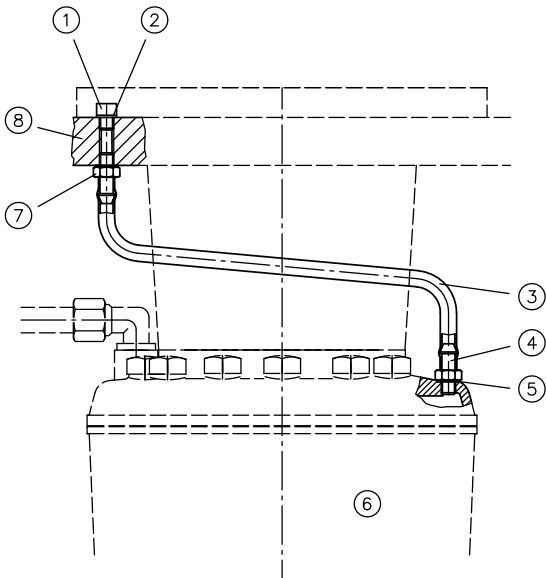
1. Connection nipple acc. to drawing 6020 070



2. Hose (NBR)



Drawing no.	L
6020 077a	220
6020 077d	420
6020 077e	500



- 1 Cylinder screw ISO 4762-M6x6-8.8-A2K \*
- 2 Sealing ring A6x10x1 DIN 7603-Cu \*
- 3 Hose should rise steadily from pump to cover plate
- 4 Connection nipple
- 5 USIT ring U 6.7x10x1
- 6 Pump
- 7 Connection nipple with USIT ring U 6.7x10x1
- 8 Cover plate

\* Parts 1 and 2 are taken from pump.

## 5.3 Operating instructions

### Note product configuration and pressure / flow rate

The statements and technical parameters in this documentation must be strictly observed.  
The instructions for the complete technical system must also always be followed.

#### **i** NOTE

- Read the documentation carefully before usage.
- The documentation must be accessible to the operating and maintenance staff at all times.
- Keep documentation up to date after every addition or update.

### Purity and filtering of the hydraulic fluid

Fine contamination can significantly impair the function of the hydraulic component. Contamination can cause irreparable damage.

#### Examples of fine contamination include:

- Metal chips
- Rubber particles from hoses and seals
- Dirt due to assembly and maintenance
- Mechanical debris
- Chemical ageing of the hydraulic fluid

#### **i** NOTE

New hydraulic fluid from the manufacturer does not necessarily have the required level of purity.  
The hydraulic fluid must be filtered during filling.

Pay attention to the cleanliness level of the hydraulic fluid to maintain faultless operation.  
(Also see cleanliness level in [Chapter 3, "Parameters"](#)).

Additionally applicable document: [D 5488/1](#) Oil recommendations

## 5.4 Disposal information

- Valve control
  - mixed scrap
- Pump housing with motor
  - electronic waste
- Tank or hydraulic accumulator, as applicable (depressurised on the gas side)
  - scrap iron
- Hydraulic fluid
  - waste oil

## 6 Other information

### 6.1 Accessories, spare parts and separate components

- Spare parts (pump elements) [D 5600](#)
- Spare parts [D 6010 H](#)

## Further information

### Additional versions

- Motor pump and hydraulic power pack type R and RG: D 6010 H
- Radial piston pump type R and RG: D 6010
- Hydraulic power pack type R and RG: D 6010 DB
- Radial piston pump type R and RG with one main pressure connection and one or two ancillary pressure connections: D 6010 S



## Further information

HAWE Hydraulik SE is a responsible development partner with application expertise and experience in more than 70 areas of mechanical engineering and plant engineering. The product range includes hydraulic power packs, constant and variable pumps, valves, sensors and accessories. The modular system is complemented by electronic components that are perfectly coordinated with the hydraulic components and that simplify control, signal evaluation and fault detection. The intelligent system solutions reduce energy consumption and operating costs. Compact drives save space and permit innovative machine design.

Across the globe, approximately 2000 employees in 16 countries and sales partners in more than 40 countries provide customers with local, professional and personal support.

The company is certified in accordance with ISO 9001, ISO 4413, ISO 50001, OHSAS 18001.



### ■ HAWE subsidiaries and service repair shops

- Germany
- Finland
- France
- Italy
- Austria
- Switzerland

### ● HAWE sales partners

- Slovenia
- Spain
- Sweden
- USA
- Canada
- Russia
- China
- India
- Japan
- Korea
- Singapore
- Australia

You can find further information on HAWE Hydraulik, your local contact and the range of hydraulics training sessions offered at: [www.hawe.com/contact](http://www.hawe.com/contact).